



5001 Tremont Ave. Davenport, IA 52807

563-386-9596 Fax 563-386-9639

<http://www.graceport.com>

VoltageVision® Voltage Indicator Fusing Issue

Updated April 30, 2010

Products: R-3W, R-3W2 (Class 1 Division 2), R-3W-SR (Solid-ON) Voltage Indicators (all products referred to as “R-3W” in this write-up)
Same principles apply to R-1A ChekVolt® Portals installations.

Applicable Standards: UL 508A Feb, 2010, National Electrical Code (NEC) NFPA 70 2008 Edition, NFPA 70E 2009 Edition, and CSA Z462.

Background:

The purpose of the NEC, as well as the UL 508A Industrial Control Panel Standard, is best summed up in Article 90 of the 2008 NEC:

“90.1 (A) Practical Safeguarding. The purpose of this Code is the practical safeguarding of persons and property from hazards arising from the **use of electricity.**”

(B) Adequacy. This *Code* contains provisions that are considered necessary for safety. Compliance therewith and proper maintenance results in **an installation that is essentially free from hazard.**“(emphasis mine)

Compared to the purpose of the NFPA 70E:

“90.1 Purpose. The purpose of this standard is to provide a practical **safe working area for employees** (emphasis) relative to the hazards arising from the use of electricity.”

90.2 Scope.

(A) Covered. This standard addresses electrical safety requirements for employee workplaces that are **necessary for the practical safeguarding of employees during activities such as the installation, operation, maintenance** (emphasis mine)”

These are two very different goals. While the NEC protects people using electricity and property, the NFPA 70E only protects employees who work with or around electricity. In very few instances these two objectives do not conflict. When a conflict exists, a hazard risk analysis needs to be performed to determine which solution poses the highest risk. Once this has been determined, then we can decide how to resolve this conflict by focusing on reducing the greater risk first. Over-current protection (fusing) of the R-3W provides us with an excellent test case.

Blown Fuse is ‘False Negative’

Getting ‘bit’ by live voltage is almost always a surprise! Far worse is an electrician starting to work on a conductor that he just tested ‘dead’, but actually is ‘live’. This is referred to as a ‘false negative’ indication, which means the voltage detector (falsely) indicated that there, was no voltage (negative). The opposite scenario is a ‘false positive’, which never hurt a soul. Since the R-3W’s only full time job is indicating voltage, **a blown fuse on its input creates a false negative indicator of voltage, which is a hazard.** A fuse also adds four connection points of failure for each phase (line-load for fuse and fuse block). In electrical safety, once you touch a live conductor there is ALWAYS an electric incident because electrical energy is instantaneous. Therefore, it is critical to avoid any chance of false-negatives.

Hazard Risk Analysis

Which risk is greater? Is it a 'false negative' voltage indication or a damaged wire inside an enclosure shorted to ground? *To be blunt, a shorted wire pales in comparison to the severe trauma and high fatality rate of an electrical incident.*

The 'Increased Hazard' Exception

The NFPA 70E recognizes that when the possibility of an increased hazard exists exceptions to the norm become an essential safety ingredient.

“Greater Hazard. Energized work shall be permitted where the employer can demonstrate that de-energizing introduces additional or increased hazards.

(2) Infeasibility. Energized work shall be permitted where the employer can demonstrate that the task to be performed is infeasible in a de-energized state due to equipment design or operational limitations.” NEC 130.1(A)(1)

The NEC makes similar statements. For example, a greater hazard is created when a fire pump motor cannot function because the overcurrent protective device on the control circuit has tripped. In electrical safety, determining zero electrical energy is 'critical' in electrical safety. Including overcurrent protection for a voltage indicator installation increases the opportunity for a false negative reading thereby *creating a hazard*.

“Exception: Overcurrent protection shall be omitted where the opening of the control circuit would create a hazard as, for example, the control circuit of a fire pump motor and the like”.
NEC 430.72(C)

A voltage indicator also offers much better electrical characteristics (see below) than the transformers that are covered under the above references [430.72(C)(1), (C)(2), (C)(3), (C)(4), and (C)(5)]. This same exception allows for even more applications of unprotected control transformer if ground fault protection is provided on the circuit [430.72(B) Exception No. 1].

Over-current Protection Design Considerations

Fusing protects both the wires and the devices from permanent damage due to excessive current flow during a short circuit. Since R-3W's installs between all 3-phases and ground, it is imperative that the failure of the R-3W does not create a 'bolted fault' condition. Consider these design facts relating to fusing the R-3W:

- **High Impedance:** R-3W's are C-UL-US Listed (file E256847, CCN: NKCR-Auxiliary Devices) for use in a UL 508A industrial control panels or UL 845 motor control centers. UL performed a single component evaluation test that insures the device would not experience a catastrophic failure due to a component failure thereby causing a direct short circuit between phases. UL determined that R-3W's are a self-protected device whereby a single component failure draws no more than 3.7mA current at 750VAC applied to the device. The large passive input resistors on each phase of the R-3W provide this current limiting function with a nominal current draw of 300µA between phase at 480VAC (Figure 1).
- **Electrical Integrity:** The potted construction adds additional electrical strength to the device. The physical presence of high voltage only extends ¾" from the rear (inside) where the leads enter the device.
- **Surge Rated:** The R-3W2 carries a CAT III(1000V) and CAT IV(600V) surge rating for reliability.
- **Integral Lead Wires:** The integral potted 18AWG UL listed 1000V rated lead wires will not 'vibrate loose' causing a short circuit to ground. Since the failure mode of the R-3W is 3.7mA, these wires should not fail due to a device failure.
- **Wire Protection:** An optional NTW conduit adapter (R-3W-DR6) provides physical protection to the wires.

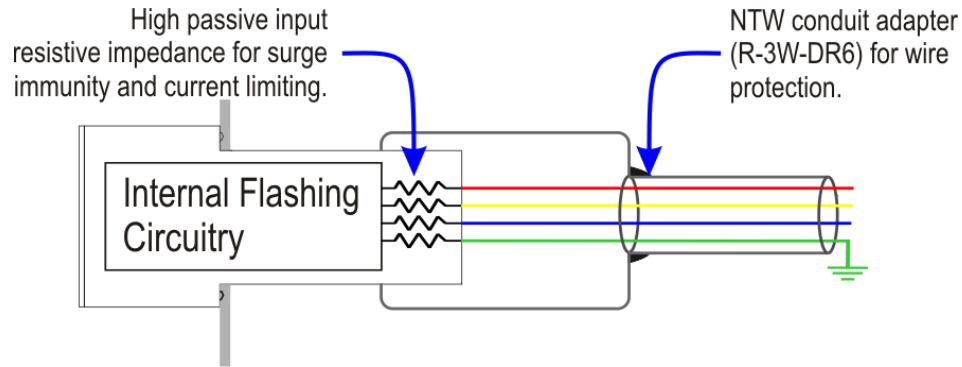

Figure 1

In conclusion, overcurrent protection will only protect R-3W's from a damaged lead wire that might short to ground or another bare conductor. If this happens, most likely the current will 'vaporize' the lead wire causing limited damage to the enclosure. Since the lead wire insulation is a flame-rated and UL-listed, it is designed to not sustain a flame.

Other Installation Options: NEC Tap Rule and the UL 508A 12" Rule

NEC 430.72(A), Table 430.72(B) allows smaller conductors to be 'tapped' off larger branch circuits. In addition, the UL 508A 40.3.2 Exception 2 allows for unprotected leads less than 12" from the device. This gives you two installation options to consider:

- Mount the R-3W within 12" of the main disconnect. The best location is on the flange or the side of the enclosure. An NPT conduit adaptor (R-3W-NPT125) for the R-3W may facilitate some other creative mounting options.
- From the main disconnect, wire to terminal blocks as per the NEC tap rule. Locate the terminal blocks within 12" of the R-3W as per figure 2.

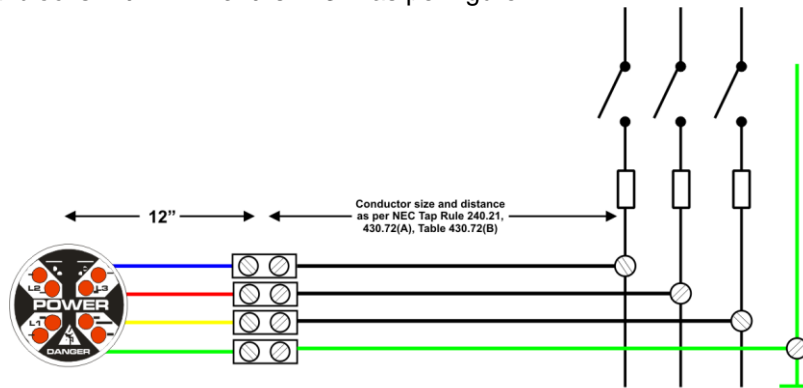

Figure 2

The NEC has been around a lot longer than the NFPA 70E. The writers of the NEC never envisioned that a safe electrical installation and electrical worker safety would conflict with each other. As shown in this write-up, these inconsistencies are usually mitigated with a little common sense and good logic.

I am looking for some healthy debate on this issue, so please feel free to pass on your comments on this document.

Regards,

Philip Allen
800-280-9517
philallen@grace-eng.com